

## Low Reference High Efficiency Boost Regulator

### FEATURES

- True Shutdown
- 700mA Output Current at 3.3V Input; 4.2V output
- 92% Efficiency from 2.7V<sub>IN</sub> to 3.3V<sub>OUT</sub>
- Wide Input Voltage Range: 2.7V to 4.5V
- 5V Fixed or Adjustable Output
- 0.3Ω Switch
- Integrated Synchronous Rectifier:0.3Ω
- Anti-Ringing Switch Technology
- Programmable Inductor Peak Current
- Logic Shutdown Control
- Low 0.8V or 0.288V Reference Voltage
- Small 10 pin DFN or MSOP Package

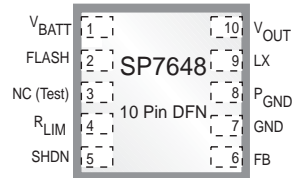

*Now Available in Lead Free Packaging*

### APPLICATIONS

- LED Driver
- Camera Flash
- Handheld Portable Devices

### DESCRIPTION

The SP7648 is an ultra-low quiescent current, high efficiency step-up DC-DC converter ideal for single cell Li-Ion or dual cell alkaline battery applications to drive various LEDs. The SP7648 combines low quiescent current and excellent light-load efficiency of PFM control. The SP7648 features synchronous rectification, a 0.3Ω charging switch, an anti-ringing inductor switch, under-voltage lockout and programmable inductor peak current. The device can be shut down by a 1nA active LOW shutdown pin. A very low 0.288V reference voltage is optimized for driving a constant current load.

### TYPICAL APPLICATION CIRCUIT

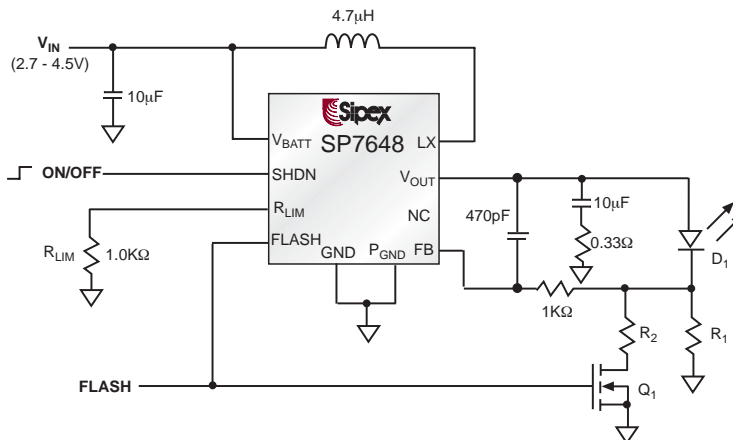

## ABSOLUTE MAXIMUM RATINGS

LX, Vo, V<sub>BATT</sub>, FLASHOUT, FB to GND pin ..... -0.3 to 6.0V  
 SHDN, FLASH ..... -0.3V to V<sub>BATT</sub> +1.0V  
 Vo, GND, LX Current ..... 2A  
 Reverse V<sub>BATT</sub> Current ..... 220mA  
 Forward V<sub>BATT</sub> Current ..... 500mA  
 Storage Temperature ..... -65 °C to 150°C

Operating Temperature ..... -40°C to +85°C  
 ESD Rating ..... 1.5kV HBM

These are stress ratings only and functional operation of the device at these ratings or any other above those indicated in the operation sections of the specifications below is not implied. Exposure to absolute maximum rating conditions for extended periods of time may affect reliability.

## ELECTRICAL SPECIFICATIONS

V<sub>BATT</sub> = V<sub>SHDN</sub> = 3.6V, V<sub>FB</sub> = ZeroV, I<sub>LOAD</sub> = 0mA, T<sub>AMB</sub> = -40°C to +85°C, V<sub>OUT</sub> = 5.0V, typical values at 27°C unless otherwise noted. The ♦ denotes the specifications which apply over full operating temperature range -40°C to +85°C, unless otherwise specified.

PARAMETER	MIN	TYP	MAX	UNITS	♦	CONDITIONS
Input Voltage Operating Range, V <sub>BATT</sub>	2.7	-	4.5	V	♦	After Startup
Output Voltage Range, V <sub>OUT</sub>	2.7	-	5.5	V	♦	
Under Voltage Lock-out/UVLO	0.5	0.61	0.7	V	♦	
Output Voltage, V <sub>O</sub>	4.6	5.0	5.4	V	♦	Internal Feedback Divider
Shutdown Current into V <sub>O</sub> , I <sub>SDO</sub>	-	1	500	nA	♦	V <sub>SHDN</sub> = ZeroV
Shutdown Current into V <sub>BATT</sub> , I <sub>SDB</sub>	-	250	750	nA	♦	V <sub>SHDN</sub> = ZeroV, V <sub>BATT</sub> = 2.7V
Efficiency		92	-	%	-	V <sub>BATT</sub> = 2.7V, I <sub>OUT</sub> = 200mA, R <sub>LIM</sub> = 2kΩ
Inductor Peak Current Limit, I <sub>PK</sub>	650	800 1600	1000	mA mA	♦ ♦	R <sub>LIM</sub> = 2kΩ, I <sub>PK</sub> = 1600/R <sub>LIM</sub> R <sub>LIM</sub> = 1kΩ, I <sub>PK</sub> = 1600/R <sub>LIM</sub>
Output Current (Note 2)	- - -	800 400 200	- - -	mA mA mA	- - -	V <sub>BATT</sub> = 2.7V, R <sub>LIM</sub> = 1kΩ V <sub>BATT</sub> = 2.7V, R <sub>LIM</sub> = 2kΩ V <sub>BATT</sub> = 2.7V, R <sub>LIM</sub> = 4kΩ
Minimum Off-Time Constant K <sub>OFF</sub>	0.5	1.0	1.5	V*μs	♦	K <sub>OFF</sub> ≤ T <sub>OFF</sub> (V <sub>OUT</sub> - V <sub>BATT</sub> )
Maximum On-Time Constant K <sub>ON</sub>	2.0	3.5	5.0	V*μs	♦	K <sub>ON</sub> ≥ T <sub>ON</sub> (V <sub>BATT</sub> )
Enable Valid to Output Stable (Note 3)	-	300	500	μs	-	I <sub>LOAD</sub> = 1mA
NMOS Switch Resistance	-	0.30	0.6	Ω	♦	I <sub>NMOS</sub> = 100mA
PMOS Switch Resistance	-	0.30	0.6	Ω	♦	I <sub>PMOS</sub> = 100mA
FB Set Voltage, V <sub>FB</sub>	0.76 0.266	0.8 0.288	0.84 0.310	V V	♦ ♦	External feedback Flash = 0 External feedback Flash = 1
FB Input Current	-	1	100	nA	♦	V <sub>FB</sub> = 1.3V
SHDN Input Voltage (Note 1) V <sub>IL</sub> V <sub>IH</sub>	- 2.0	- -	0.5 -	V V	♦ ♦	V <sub>BATT</sub> = 2.7V V <sub>BATT</sub> = 2.7V
SHDN Input Current	-	1	100	nA	♦	
LX Pin Leakage	-	-	3	μA	-	
FLASH Threshold V <sub>IL</sub> V <sub>IH</sub>	- 1.0	- -	0.4 -	V V		

**Note 1:** SHDN must transition faster than 1V/100mS for proper operation.

**Note 2:** Output Current  $I = \left\{ \frac{V_{IN}}{V_{OUT}} \right\} \times \text{Efficiency} \times \left\{ \text{Inductor Peak Current} - \frac{\text{Inductor Ripple Current}}{2} \right\}$

**Note 3:** Guaranteed by Design.

PIN NUMBER	PIN NAME	DESCRIPTION
1	V <sub>BATT</sub>	Battery Voltage. The startup circuitry is powered by this pin. Battery Voltage is used to calculate switch off time: $T_{OFF} = K_{OFF} / (V_{OUT} - V_{BATT})$ . When the battery voltage drops below 0.61V the SP7648 goes into an undervoltage lockout mode (UVLO), where the part is shut down.
2	FLASH	Reference Control Input. Internal Reference defaults to 0.8V if FLASH = LOW and 0.288V if FLASH = HIGH.
3	NC (Test)	No connection. This pin is bonded out for test purposes only and must be left floating in all applications.
4	R <sub>LIM</sub>	Current Limit Resistor. By connecting a resistor R <sub>LIM</sub> from this pin to ground the inductor peak current is set by $I_{PEAK} = 1600/R_{LIM}$ . The range for R <sub>LIM</sub> is 9kΩ (for 180mA) to 1.KΩ (for 1.6A).
5	SHDN	Shutdown Not. Tie this pin high to V <sub>BATT</sub> , for normal operation. Pull this pin to ground to disable all circuitry inside the chip.
6	FB	Feedback. Connect this pin to GND for fixed +5V operation. Connect this pin to a resistor voltage divider between V <sub>OUT</sub> and GND for adjustable output operation.
7	GND	Ground. Connect to ground plane.
8	PGND	Power Ground. The inductor charging current flows out of this pin.
9	LX	Inductor Switching Node. Connect one terminal of the inductor to the positive terminal of the battery. Connect the second terminal of the inductor to this pin. The inductor charging current flows into LX, through the internal charging N-channel FET, and out the PGND pin.
10	V <sub>OUT</sub>	Output Voltage. The inductor current flows out of this pin during switch off-time. It is also used as the internal regulator voltage supply. Connect this pin to the positive terminal of the output capacitor.

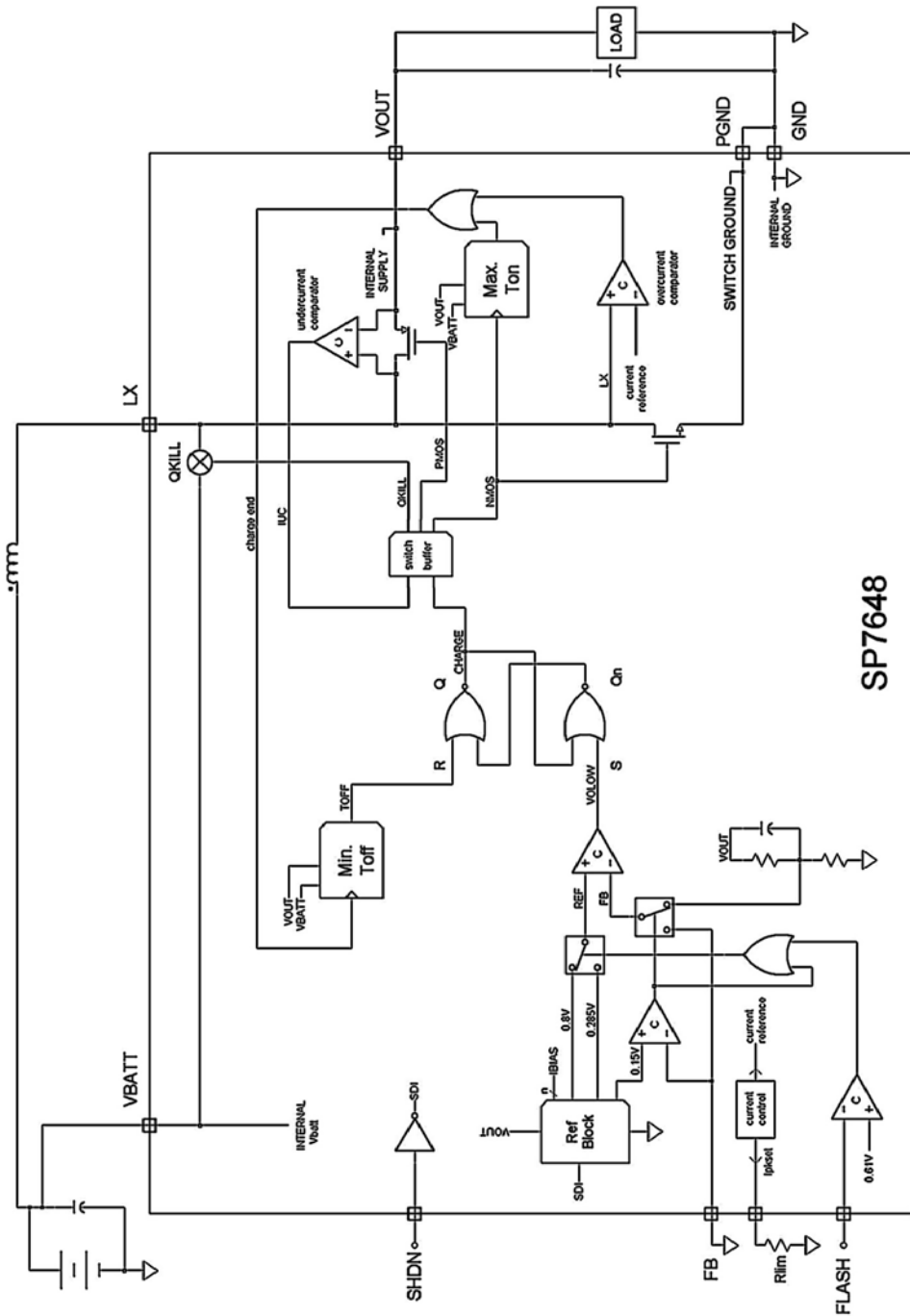

SP7648

**DETAILED  
DESCRIPTION**

The SP7648 is a step-up DC-DC converter with an input voltage operation range from 2.7V to 4.7V. In addition to the main 0.3Ω internal NMOSFET switch the SP7648 has an internal synchronous rectifier, thereby increasing efficiency and reducing the space and cost of an external diode. An internal inductive-damping switch significantly reduces inductive ringing for low noise-high efficiency operation. If the supply voltage drops below 0.61V the SP7648 goes into under voltage lockout, thus opening both internal switches. The inductor peak current is externally programmable to allow for a range of inductor values.

devices, the inductor and input & output filter capacitors should be soldered with their ground pins as close together as possible in a star-ground configuration. The V<sub>OUT</sub> pin must be bypassed directly to ground as close to the SP7648 devices as possible (within 0.2in or 5mm). The DC-DC converter and any digital circuitry should be placed on the opposite corner of the PC board as far away from sensitive RF and analog input stages. Noisy traces, such as from the LX pin, should be kept away from the voltage-feedback V<sub>FB</sub> node and separated from it using grounded copper to minimize EMI. See the SP7648EB Evaluation Board Manual for PC Board Layout design details.

**CIRCUIT  
LAYOUT**

Printed circuit board layout is a critical part of a power supply design. Poor designs can result in excessive EMI on the feedback paths and on the ground planes with applications involving high switching frequencies and large peak currents. Excessive EMI can result in instability or regulation errors. All power components should be placed on the PC board as closely as possible with the traces kept short, direct, and wide (>50mils or 1.25mm). Extra copper on the PC board should be integrated into ground as a pseudo-ground plane. On a multilayer PC board, route the star ground using component-side copper fill, then connect it to the internal ground plane using vias. For the SP7648

**CONTROL SCHEME**

A minimum off-time, current limited pulse frequency modulation (PFM) control scheme combines the high output power and efficiency of a pulse width modulation (PWM) device with the ultra low quiescent current of the traditional PFM. At low to moderate output loads the PFM control provides higher efficiency than traditional PWM converters are capable of delivering. At these loads the switching frequency is determined by a minimum off-time (T<sub>OFF, MIN</sub>) and a maximum on-time (T<sub>ON, MAX</sub>) where:

$$T_{OFF} \leq K_{OFF} / (V_{OUT} - V_{BATT})$$

$$T_{ON} \geq K_{ON} / V_{BATT}$$

$$K_{OFF} = 1.0V\mu s$$

$$K_{ON} = 3.5 V\mu s$$

At light loads (as shown in plot A in Figure 1) the charge cycle will last the maximum value for  $t_{ON}$ : For a 3V battery this would be as follows:  $T_{ON} = K_{ON} / V_{BATT} = 3.5V\mu S / 3V = 1.17\mu S$ . The current built up in the coil during the charge cycle gets fully discharged in the discontinuous conduction mode (DCM). When the current in the coil has reached zero, the synchronous rectifier switch is opened and the voltage across the coil (from  $V_{BATT}$  to LX) is shorted internally to eliminate inductive ringing. With increasing load (as shown in plot B in Figure 1) this inductor damping time becomes shorter, because the output will quickly drop below its regulation point due to heavier load. If the load current increases further, the SP7648 enters continuous conduction mode (CCM) where there is always current flowing in the inductor. The charge time remains at maximum  $T_{ON}$  as long as the inductor peak

current limit is not reached as shown in plot C in Figure 1. The inductor peak current limit can be programmed by tying a resistor  $R_{LIM}$  from the  $R_{LIM}$  pin to ground where:

$$I_{PEAK} = 1600 / R_{LIM}$$

When the peak current limit is reached the charge time is short-cycled. In plot D of Figure 1, the switch current reaches the peak current limit during the charge period which ends the charge cycle and starts the discharge cycle. However, full load is not yet achieved because at the end of the minimum discharge time the output was still within regulation. Maximum load is reached when this discharge time has shrunk to the minimum allowed value  $T_{OFF}$  as shown in Plot E of Figure 1.

**COMPONENT SELECTION**

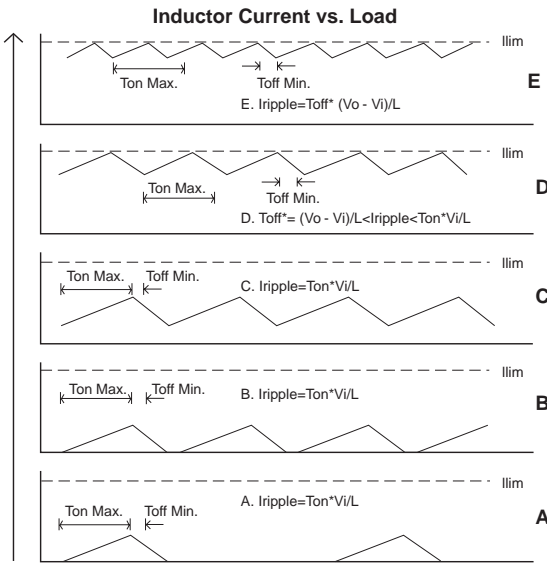

Figure 1. Inductor Current vs. Load

Selection of capacitors for SP7648 power supply circuits can be made through the use of the Component Selection Table. Capacitor equivalent series resistance (ESR) in the range of 0.2 to 0.3Ω is a requirement for obtaining sufficient output voltage ripple for the SP7648 to properly regulate under its load. For example, in the SP7648 application circuit a 10μF, 10V, X5R, surface mount ceramic output filter capacitor is used. Ceramic capacitors have an ESR too low to produce enough output ripple for the SP7648 to regulate the output; therefore, a 0.33Ω resistor is added in series with the 10μF capacitor at the  $V_{OUT}$  pin. Designers should select input and output capacitors with a rating exceeding the inductor current ripple, which is typically set by the inductor value and the  $K_{ON}$  value as given in the following relationship:

$$I_{L(RIPPLE)} = K_{ON}/L, \text{ where } K_{ON} = 3.5V*\mu S$$

INDUCTORS - SURFACE MOUNT						
Inductance (uH)	Manufacturer/Part No.	Inductor Specification				Manufacturer Website
		Series R ohms	Isat (A)	Size LxWxH (mm)	Inductor Type	
<b>4.7</b>	<b>Würth Elektronik 744042004</b>	<b>0.070</b>	<b>1.70</b>	<b>4.8x4.8x1.8</b>	<b>Shielded Ferrite Core</b>	<a href="http://www.wv-online.de">www.wv-online.de</a>
4.7	TDK SLF6025T-4R7M1R5-PF	0.031	1.50	6.0x6.0x2.5	Shielded Ferrite Core	<a href="http://www.tdk.com">www.tdk.com</a>
4.7	Coilcraft MSS6122-4R7MX	0.065	1.85	6.1x6.1x2.2	Shielded Ferrite Core	<a href="http://www.coilcraft.com">www.coilcraft.com</a>
6.8	Würth Elektronik 744042006	0.080	1.50	4.8x4.8x1.8	Shielded Ferrite Core	<a href="http://www.wv-online.de">www.wv-online.de</a>
6.8	TDK SLF6025T-6R8M1R3-PF	0.044	1.30	6.0x6.0x2.5	Shielded Ferrite Core	<a href="http://www.tdk.com">www.tdk.com</a>
6.8	Coilcraft MSS6122-6R8MX	0.100	1.45	6.1x6.1x2.2	Shielded Ferrite Core	<a href="http://www.coilcraft.com">www.coilcraft.com</a>
CAPACITORS - SURFACE MOUNT						
Capacitance (uF)	Manufacturer/Part No.	Capacitor Specification				Manufacturer Website
		ESR ohms (max)	Ripple Current 10C Rise (A)	Size LxWxH (mm)	Voltage (V)	
<b>10</b>	<b>TDK C2012X5R0J106M</b>	<b>0.020</b>	<b>1.70</b>	<b>2.0x1.2x1.35</b>	<b>6.3</b>	<b>X5R Ceramic</b>
10	Murata GRM21BR60J106KE19L	0.020	1.70	2.0x1.2x1.35	6.3	X5R Ceramic
MOSFETS - SURFACE MOUNT						
MOSFET type	Manufacturer/Part No.	MOSFET Specification			MOSFET Specifications	Manufacturer Website
		RDS(on) ohms	Id (A)	Package Size		
<b>NMOS</b>	<b>Vishay Si1400DL</b>	<b>0.190</b>	<b>1.70</b>	<b>SC70-6</b>	<b>20V, Vgs = 2.5V, Pd = 0.5W</b>	<a href="http://www.vishay.com">www.vishay.com</a>
NMOS	Fairchild FDN337N	0.070	2.20	SOT23-3	30V, Vgs = 2.5V, Pd = 0.5W	<a href="http://www.fairchildsemi.com">www.fairchildsemi.com</a>
RESISTORS - LOW VALUE SURFACE MOUNT						
Resistor Ref. Des.	Manufacturer/Part No.	Resistor Specification			Resistor Specifications	Manufacturer Website
		Resistance ohms	Pd (W)	Package Size		
<b>Rc, R2</b>	<b>Vishay CRCW0603R33F</b>	<b>0.33</b>	<b>0.10</b>	<b>0603</b>	<b>Thick Film 1% or 5%</b>	<a href="http://www.vishay.com">www.vishay.com</a>
Rc, R2	Vishay CRCW0603R22F	0.22	0.10	0603	Thick Film 1% or 5%	<a href="http://www.vishay.com">www.vishay.com</a>

Note: Components highlighted in **bold** are those used on the SP7648EB Evaluation Board.

Table 1: Component Selection

For the example, a 10µH inductor would have an inductor current ripple of 350mA, while a 4.7µH inductor would have an inductor current ripple value of 740mA. Do not allow tantalum capacitors to exceed their ripple-current ratings. An input filter capacitor can reduce peak currents drawn from the battery and improve efficiency. For most applications, use the same capacitor for the input and output.

Low-ESR tantalum capacitors are acceptable provided they meet the ESR requirement of 0.2Ω to 0.3Ω. In selecting an inductor, the saturation current specified for the inductor needs to be greater than the SP7648 peak current to avoid saturating the inductor, which would result in a loss of efficiency and could damage the inductor. The SP7648 evaluation board uses a Würth 4.7µH inductor with an ISAT value of 1.7A and a DCR of 0.065Ω, which handles the IPEAK of 1.6A of the SP7648 and will deliver high efficiencies. Other inductors could be selected provided their ISAT is greater than the IPEAK of the SP7648.

## VOUT PROGRAMMING

The SP7648 can be programmed as either a voltage source or a current source. To program the SP7648 as voltage source, the SP7648 requires 2 feedback resistors R1 & R2 to control the output voltage. To set VOUT in the voltage mode, use the equation:

$$R1 = [(V_{OUT}/0.8)-1] * R2, \text{ where flash} < 0.4V,$$

$$R1 = [(V_{OUT}/0.288)-1] * R2, \text{ where flash} > 1.0V$$

## USING THE RLIM FUNCTION

The peak inductor current, IPEAK, is programmed externally by the RLIM resistor connected between the RLIM pin and GND. The peak inductor current is defined by:

$$I_{PEAK} = 1600/R_{LIM}$$

The saturation current specified for the inductor needs to be greater than the peak

current to avoid saturating the inductor, which would result in a loss in efficiency and could damage the inductor. The SP7648 evaluation board uses a  $R_{LIM}$  value of  $1K\Omega$  for an  $I_{PEAK} = 1.6A$  to allow the circuit to deliver up to 700mA for  $V_{IN} = 3.3V$  and  $V_{OUT} = 4.2V$ . Other values could be selected using the above relationships.

### USING THE FLASH CONTROL PIN

The SP7648 will regulate the output by the equations above depending on the state of the FLASH pin. When the FLASH pin is low ( $<0.4V$ ), the internal reference voltage is defined as 0.8V. When the FLASH pin is high ( $>0.4V$ ), the internal reference voltage is defined as 0.288V. This allows the use of smaller values for the sense resistor for current regulation mode. This improves efficiency and reduces the physical size of the sense resistor. An external MOSFET switch can be used to change the sense resistor when changing to the Flash Mode.

### HIGH BRIGHTNESS WHITE LED

For the high brightness LumiLED white LED application, the SP7648 is generally programmed as a current source. The bias resistors R1 and R2 are used to set the operating current of the white LED with the equation:

$$R = V_{FB}/I_F$$

where  $V_{FB}$  is 0.8V in torch mode and 0.288V in flash mode,  $I_F$  is the operating current of

the LED. To set the operating current to be about 200mA in torch mode, the flash pin is forced low, R2 is selected as  $0.8V/0.2 = 4\Omega$ , as shown in the typical application circuit. To set the operating current to 700mA in flash mode, the flash pin is forced high, R is selected as  $0.288V/0.41\Omega = 700mA$ . In reality R in Flash includes the series MOSFET  $R_{DSON}$  and the parallel combination of R2 =  $4\Omega$  shown by the formula:

$$R \text{ in Flash} = \frac{\{R_1 \times (R_2 + Q_1 R_{DSON})\}}{\{R_1 + R_2 + Q_1 R_{DSON}\}}$$

If the SP7648 is powered up before the LED is plugged in, the circuit will bring the feedback pin to ZeroV and the SP7648 has a feature to set the output voltage to be 5V. Once the LED is plugged in, the feedback pin will go up to 0.8V in torch mode or 0.288V in flash mode and begin to regulate. The output voltage will go from 5V to  $V_F + V_{FB}$ , where  $V_F$  is the forward voltage of the LED. When the LED is open, the feedback pin voltage will go to ZeroV and the output voltage will go to 5V which will protect the part from overvoltage at the output.

One approach to control LED brightness is to apply a PWM signal to the SHDN input of the SP7648. In this case, the output current will be equal to the product of  $V_{REF}/R1$  and the average duty cycle at the SHDN pin. An optional 10K $\Omega$  potentiometer may also be used for dimming the LED current by varying the potentiometer between low brightness and full brightness.

If the FB pin is pulled below 150mV the output will default to 5V defined by an internal resistor divider.



# TYPICAL PERFORMANCE CHARACTERISTICS

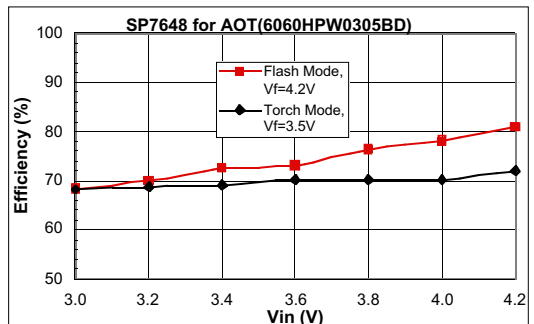
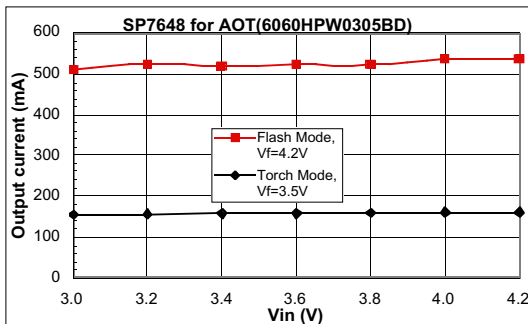
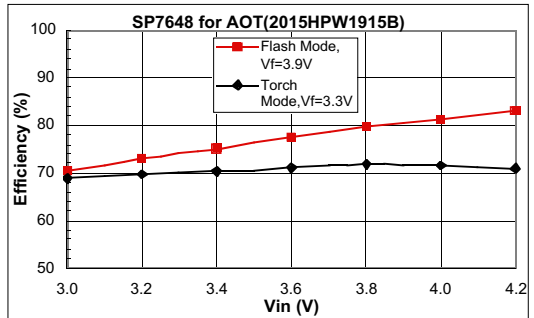
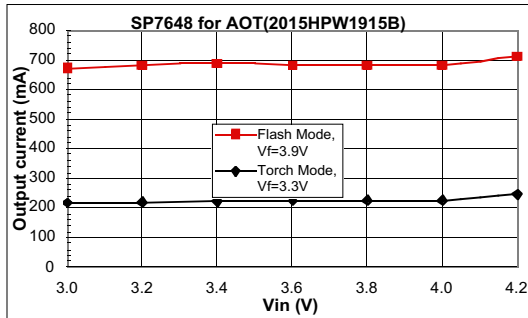
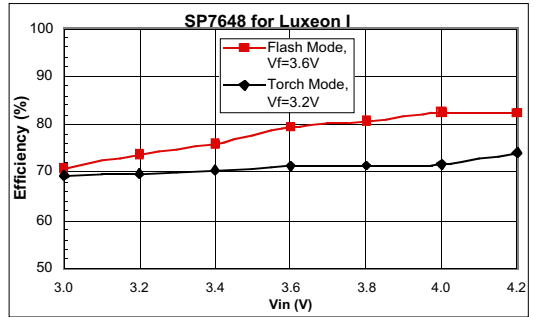
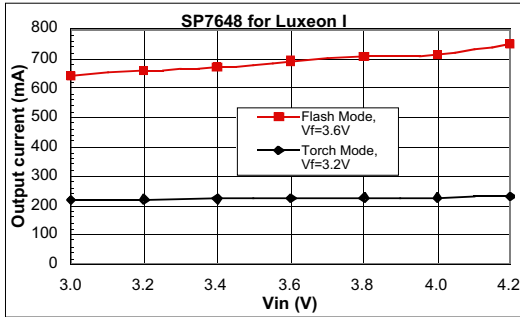

# TYPICAL PERFORMANCE CHARACTERISTICS

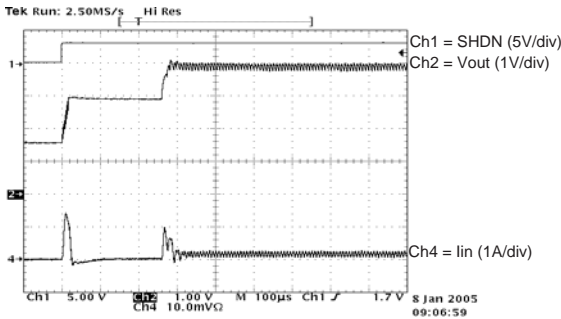

**Startup 200mA Torch, Vin = 3.6V, Vout = 3.9V**

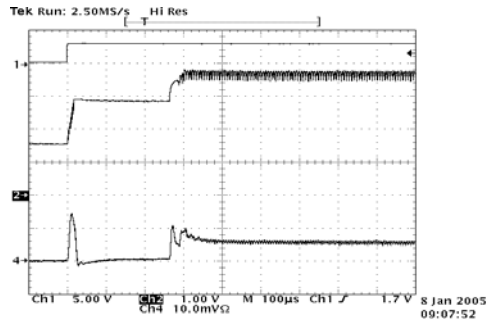

**Startup 700mA Flash, Vin = 3.6V, Vout = 3.65V**

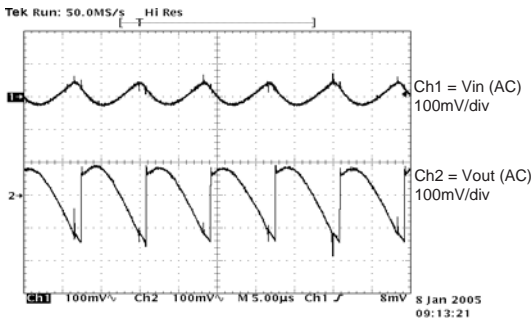

**Ripple 200mA Torch, Vin = 3.6V, Vout = 3.9V**

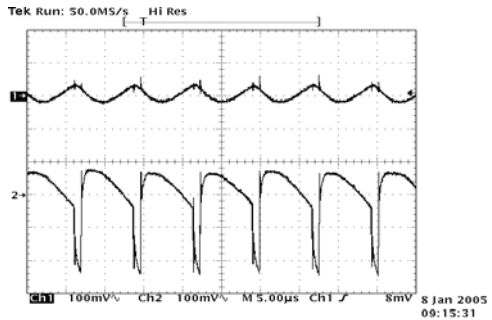

**Ripple 700mA Flash, Vin = 3.6V, Vout = 3.65V**

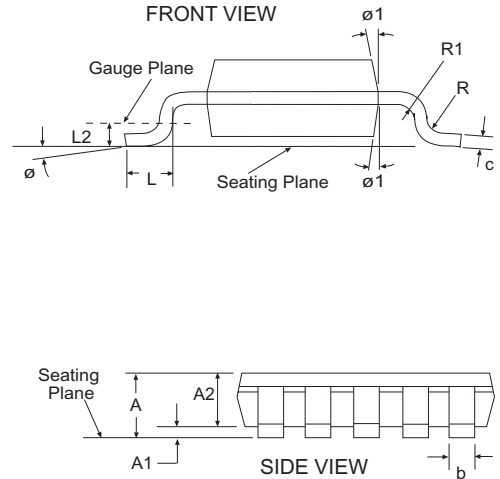
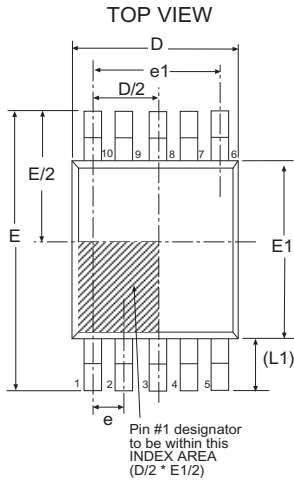

10 Pin MSOP JEDEC MO-187 Variation BA						
SYMBOL	Dimensions in Millimeters: Controlling Dimension			Dimensions in Inches Conversion Factor: 1 Inch = 25.40 mm		
	MIN	NOM	MAX	MIN	NOM	MAX
A1	0.00	-	0.15	0.000	-	0.006
c	0.08	-	0.23	0.004	-	0.009
R	0.07	-	-	0.003	-	-
R1	0.07	-	-	0.003	-	-
ø	0°	-	8°	0°	-	8°
ø1	5°	-	15°	5°	-	15°
A	-	-	1.10	-	-	0.043
A2	0.75	0.85	0.95	0.030	0.034	0.038
b	0.17	-	0.33	0.007	-	0.013
D	3.00 BSC			0.118 BSC		
E	4.90 BSC			0.193 BSC		
E1	3.00 BSC			0.118 BSC		
e	0.50 BSC			0.020 BSC		
e1	2.00 BSC			0.079 BSC		
L	0.40	0.60	0.80	0.016	0.024	0.032
L1	0.95 REF			0.037 REF		
L2	0.25 BSC			0.010 BSC		
SIPEX Pkg Signoff Date/Rev:				JL Aug09-05 RevA		

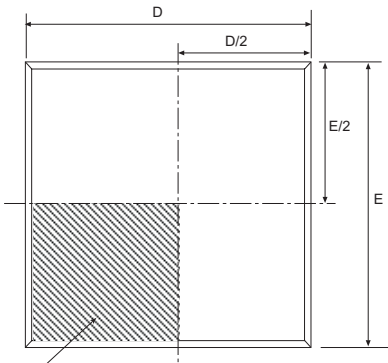

Pin1 Designator  
to be within this  
INDEX AREA  
(D/2 x E/2)

TOP VIEW

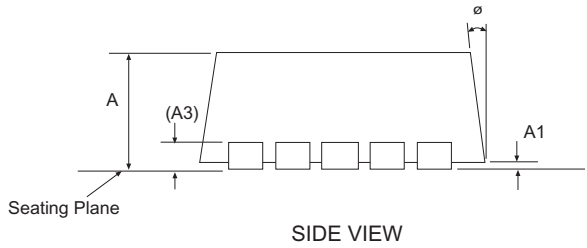

SIDE VIEW

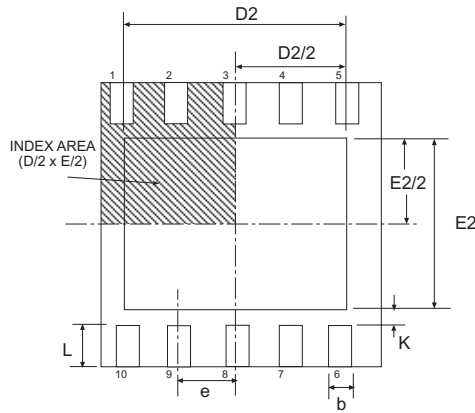

BOTTOM VIEW

3x3 10 Pin DFN		JEDEC MO-229		VARIATION VEED-5		
SYMBOL	Dimensions in Millimeters: Controlling Dimension			Dimensions in Inches Conversion Factor: 1 Inch = 25.40 mm		
	MIN	NOM	MAX	MIN	NOM	MAX
A	0.80	0.90	1.00	0.032	0.036	0.039
A1	0.00	0.02	0.05	0.000	0.001	0.002
A3	0.20 REF			0.008 REF		
K	0.20	-	-	0.008	-	-
ø	0°	-	14°	0°	-	14°
b	0.18	0.25	0.30	0.008	0.010	0.012
D	3.00 BSC			0.119 BSC		
D2	2.20	-	2.70	0.087	-	0.106
E	3.00 BSC			0.119 BSC		
E2	1.40	-	1.75	0.056	-	0.069
e	0.50 BSC			0.020 BSC		
L	0.30	0.40	0.50	0.012	0.016	0.020
SIPEX Pkg Signoff Date/Rev:				JL Aug09-05 / RevA		

<b>Part Number</b>	<b>Operating Temperature Range</b>	<b>Package Type</b>
SP7648ER .....	-40°C to +85°C .....	10 Pin DFN
SP7648ER/TR .....	-40°C to +85°C .....	10 Pin DFN
SP7648EU .....	-40°C to +85°C .....	10 Pin MSOP
SP7648EU/TR .....	-40°C to +85°C .....	10 Pin MSOP

Available in lead free packaging. To order add "-L" suffix to part number.

Example: SP7648ER/TR = standard; SP7648ER-L/TR = lead free

/TR = Tape and Reel

Pack quantity is 3,000 for DFN, and 2,500 for MSOP.